

Instruction Manual



Thank you for choosing a high-quality DAYTONA VELONA80 display instrument. With proper installation and connection, you will have long-lasting pleasure with this high-quality product when used as intended.

When installing, please make sure that the speed indicator is located in the immediate view of the driver. Attach the housing securely to the enclosed V-Bracket or mount with an at least equivalent holder permanently to the bike. Do not use longer screws to connect the holder to the housing, as longer screws can damage the instrument's internal components. Attach the instrument in a way that no part obstructs or restricts the steering. Route the wiring in such a way, that the full steering angle works in both directions without hindrance and no cables are pinched or under tension when the steering moves. Protect the cabling, also in the long term, against chafing and damage during the constantly occurring steering movements.

Read this assembly and installation manual before installing and operating the display instrument. Proper installation and electric connection requires technical expertise, special tools and skilled craftsmanship. If you are unsure about the installation, have it done, for your own safety, by a trained mechanic.

CAUTION

- Read all instructions before use.
- Needs to purchase the optional speed sensor if the vehicle does NOT come with an electrical speed sensor. Or use a converter (sold separately) that turns mechanical movement into electrical pulse, if the vehicle comes with a mechanical speedometer cable. (See the optional parts section in this manual.)
- Designed for a 12V system vehicle. VELONA gauges do NOT work with a 6V system or a battery-less system.
- VELONA gauges might not work normally when used together with other device that emits much noise.
- Use VELONA gauges for the intended purpose of use.
- VELONA gauges is for universal use, so it needs wiring for installation. Do the wiring referring to the vehicle owner's manual. (If you are not sure about installation, consult an experienced dealer.)
- Do NOT disassemble VELONA gauges. It may be damaged and water may come in.
- Do NOT leave VELONA gauges in high heat when not used for a long time.
- Do NOT hit, drop or give a shock on VELONA gauges. It may be damaged.
- Avoid contact with gasoline, brake fluid or other chemicals. It may be damaged.
- After installation, check to see if all the parts are correctly installed, and to see if all the screws are properly tightened.
- Inspect all installed parts after 100km driving. Periodical inspection is required every 500km(300mile). If anything unusual found while driving, pull over at a safe place to check.

PRODUCT FEATURES

- Stepping motor-driven speedometer
- Stainless steel + black painted
- KM/H or MPH selectable
- Odometer (NOT Resettable) : 0.0-99,999.9km (mile)
- Dual Trip Meter (Resettable) : 0.0-99,999.9km (mile)
- RPM Meter : 0-20,000rpm
- Ability to connect to OEM speed sensor, if the vehicle is equipped with an electrical speed sensor.
- Voltmeter : 0.0-18.0V
- Maximum speed memory and recall
- Maximum rpm memory and recall
- Indicators (turn signal[L/R], high beam, neutral, warning)
- Shift up warning
- Power DC9-16V (regular 12V)

COMPONENTS

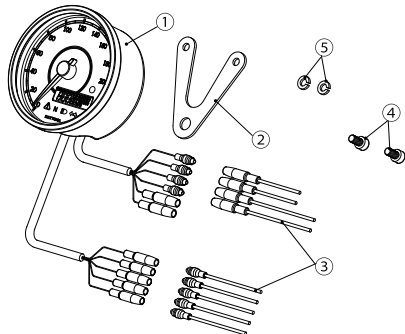

| NO. | DESCRIPTION | REMARKS | Q'TY |
|-----|--------------------|---------|------|
| ① | Gauge Unit | | 1 |
| ② | V-Bracket | | 1 |
| ③ | Extension Wire Set | 9 pcs | 1set |
| ④ | Cap Screw | M5x10 | 2 |
| ⑤ | Spring Washer | M5 | 2 |

INSTALLATION

- ⚠ Wrong wiring may cause malfunction of the gauge. Make sure to have correct wiring.
- ⚠ Disconnect the ground wire from the negative post of vehicle's battery before installation.
- ⚠ The Red wire is to be connected to the wire that gives current when the main switch is turned on.

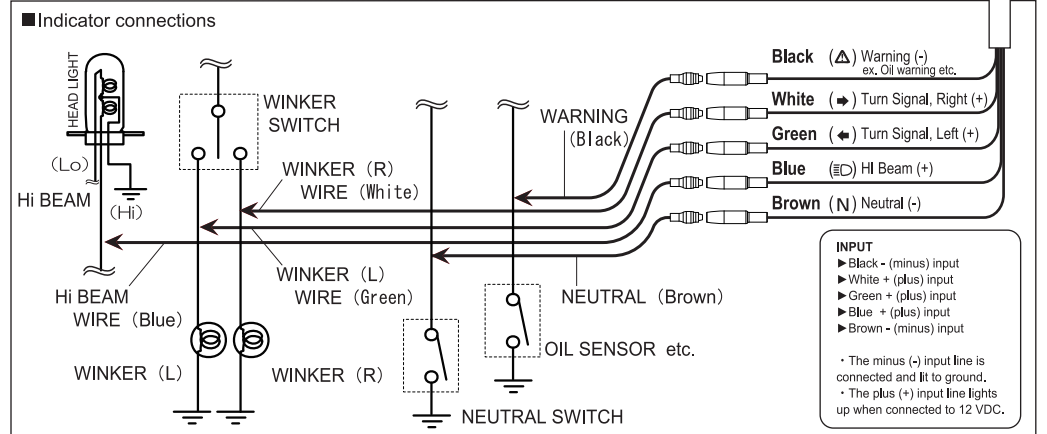
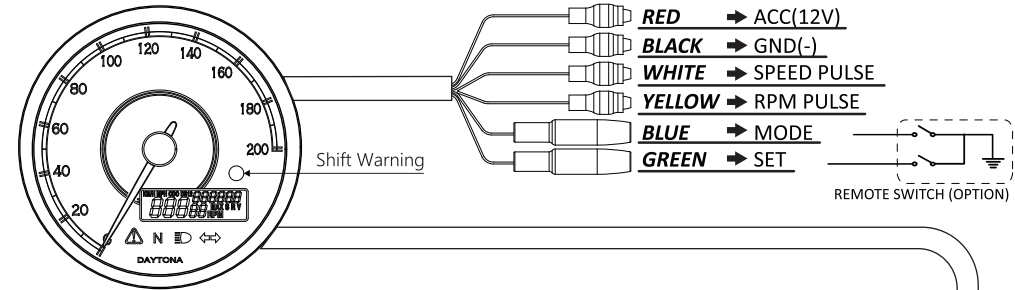

RPM pulse detection <Three options>

| From ignition coil Recommended | From spark plug code | For 2000&up Harley-Davidson only |
|---|--|--|
| <p>Pulse Wire</p> <p>Ignition Coil</p> <p>YELLOW</p> <p>Connect the yellow wire to the positive terminal/wire of the ignition coil</p> | <p>Wind the yellow wire 5-6 times on the spark plug code, and then tape to fix it.</p> | <p>BLACK</p> <p>RED</p> <p>YELLOW</p> <p>Crank Position Sensor</p> <p>Connect the yellow wire to the red wire of the vehicle's crank position sensor</p> |
| <p>⚠ Connect RPM pulse correctly. Wrong wiring causes malfunction of the gauge. If the RPM is unstable, insert a Resistance 1M ohm into the RPM Pulse line.</p> | | |

ATTENTION! Wiring alone will not make VELONA display correct speed or RPM values. Needles may not even move after wiring.

To calibrate and test your VELONA, please see the next page for instructions.

