



FITTING INSTRUCTIONS FOR LSR0001
LUGGAGE SIDE RAILS
YAMAHA TÉNÉRÉ 700 2019-



THIS KIT CONTAINS THE ITEMS PICTURED AND LABELLED OVER PAGE.

SOME PARTS MAY BE SHOWN FOR CLARITY OF INSTRUCTIONS ONLY.

DO NOT PROCEED UNTIL YOU ARE SURE ALL PARTS ARE PRESENT.

PLEASE READ ALL INSTRUCTIONS BEFORE PROCEEDING.

**IF IN ANY DOUBT WHEN FITTING OUR PRODUCTS, CONSULT ONE OF OUR DEALERS
OR HAVE FITTED BY A QUALIFIED TECHNICIAN.**

PLEASE NOTE THAT THE WAY THE KIT IS PACKED DOES NOT NECESSARILY REPRESENT THE WAY OF
MOUNTING TO THE BIKE.

IN THE EVENT OF RUBBER WASHERS BEING USED TO HOLD COMPONENTS ONTO BOLTS,
THESE RUBBER WASHERS CAN BE THROWN AWAY.

DIGITAL COPIES OF THESE INSTRUCTIONS ARE AVAILABLE FROM:

WWW.RG-RACING.COM

R&G Racing
Unit 1, Shelley's Lane, East Worldham, Alton, Hampshire, GU34 3AQ
Tel: +44 (0)1420 89007 Fax: +44 (0)1420 87301 www.rg-racing.com Email: info@rg-racing.com



<u>TOOLS REQUIRED</u>	<u>GENERAL TORQUE SETTINGS</u>
<ul style="list-style-type: none"> • 13mm SPANNER • 13mm SOCKET & WRENCH • T40 TORX TOOL 	M4 BOLT = 8Nm M5 BOLT = 12Nm M6 BOLT = 15Nm M8 BOLT = 20Nm M10 BOLT = 40Nm M12 BOLT = 40Nm

LEGEND

ITEM NO.	DESCRIPTION	QTY
ITEM 1	SMW0183 LHS LUGGAGE RACK	1
ITEM 2	SMW0183 RHS LUGGAGE RACK	1
ITEM 3	SMW0185 LHS MOUNTING BRACKET	1
ITEM 4	SMW0186 RHS MOUNTING BRACKET	1
ITEM 5	S1314 MOUNTING SPACER	4
ITEM 6	M8 x 1.25 x 80.00mm HEX HEAD BOLT (UPPER MOUNTS)	4
ITEM 7	M8 x 1.25 x 20mm HEX HEAD BOLT (LOWER MOUNTS)	2
ITEM 8	M8 x 1.25 x 25mm HEX HEAD BOLT (FOOTREST MOUNTS)	4
ITEM 9	M8 x 1.25 NYLOC NUT	2
ITEM 10	M8 WASHER OD=19mm	12
ITEM 11	M8 HEX HEAD BOLT COVER/CAP	6



LHS/RHS EXPLODED ASSEMBLY VIEW

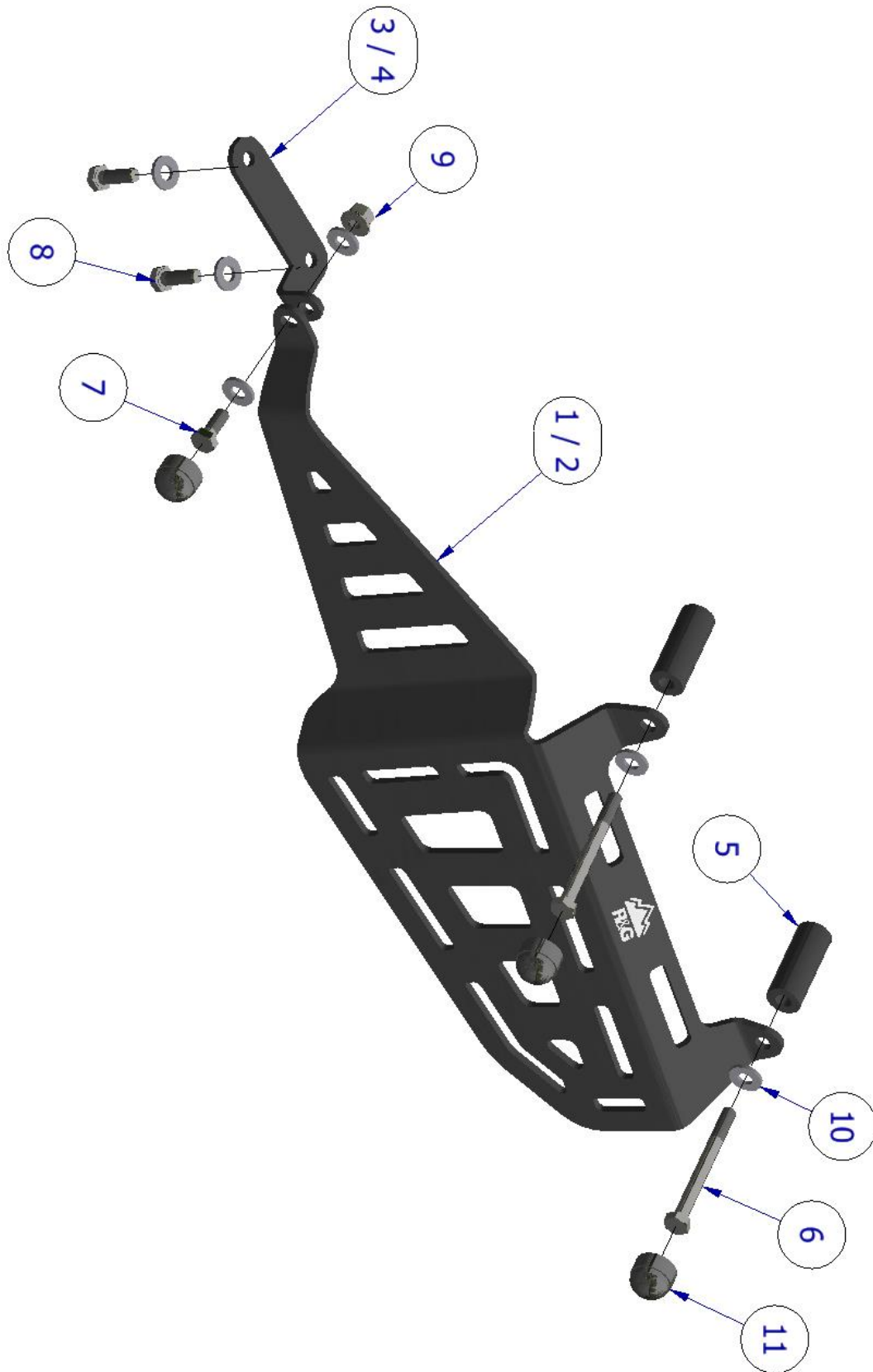



FITTING PICTURES

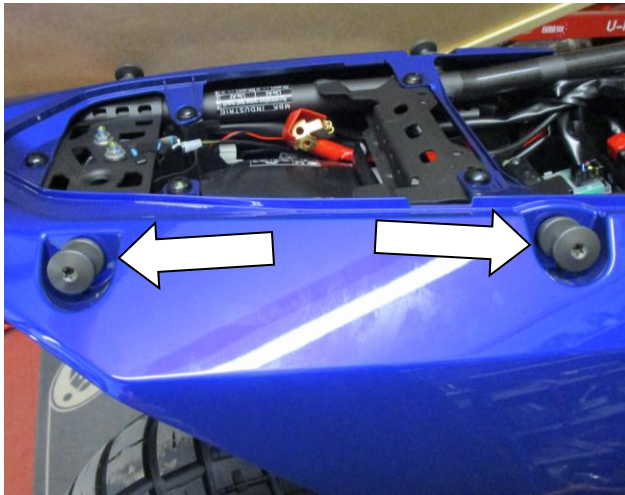

Picture 1



Picture 2



Picture 3



Picture 4



Picture 5



Picture 6



FITTING INSTRUCTIONS

- Remove the original hooks on both sides of the bike as shown in picture 1, using a T40 Torx tool.
- Remove both pillion footrests as shown in picture 2 (these can be re-fitted later, if desired).
- **If not re-fitting the footrests:** starting on the LHS of the bike, using a 13mm socket and wrench, fit the LHS mounting bracket **(item 3)** with 2 of the included M8 x 25mm bolts **(item 8)** and washers **(item 10)**, as shown in picture 3. The mounting tab should be pointing upwards and towards the rear of the bike, as shown in the diagram on page 3.
- **If re-fitting the footrests:** sandwich the LHS mounting bracket **(item 3)** between the mounting holes and the footrest mounting surface and secure with the original bolts.
- Slide a washer **(item 10)** over the 2x included longer M8 x 80mm bolts **(item 6)**, then slide through the upper mounting holes of the LHS luggage rack **(item 1)**. Place a spacer **(item 5)** over the exposed bolt length, then offer up to the original hook mounting holes, as shown in picture 4. Tighten the bolts using a 13mm socket and wrench, to give a structure as shown in picture 5.
- Align the lower mounting hole of the luggage rack with the tab hole of the mounting bracket previously fitted, then secure together using one of the included M8 x 20mm bolts **(item 7)**, washers **(item 10)** and M8 Nyloc nuts **(item 9)**. Tighten using a 13mm socket and wrench, whilst holding the nut with a 13mm spanner, as shown in picture 6.
- Repeat previous steps for the RHS of the bike, then fully tighten all bolts. Finally, fit a bolt cap **(item 11)** to each of the bolt heads.
- Fit your choice of soft luggage, securing to the racks using suitable straps if required.
- **If fitting particularly large/long luggage that overhangs the racks, you will additionally need to fit an R&G exhaust heat shield (product code - ESG0002BK) to prevent the luggage from contacting the exhaust silencer during use.**

Before riding with luggage fitted, ensure that all luggage is fully secured and will not contact any part of the chain or exhaust silencer during use.

Failure to do so will result in damage to the luggage and bike and may cause serious injury or death.



ISSUE 1 - 02/03/2021 (FB)

CONSUMER NOTICE

The catalogue description and any exhibition of samples are only broad indications of the Products and R&G may make design changes which do not diminish their performance or visual appeal and supplying them in such state shall conform to the order. The Buyer acknowledges no representation or warranty (other than as to title) has been given or will apply to the Products other than those in R&G's order or confirmation and the Buyer confirms it has chosen the Products as being of merchantable quality and suitable for its particular purposes. Where R&G fits the Products or undertakes other services it shall exercise reasonable skill and care and rectify any fault free of charge unless the workmanship has been disturbed. The Buyer is responsible for ensuring that the warranty on the motorcycle is not affected by the fitting of the Products. On return of any defective Products R&G shall at its option either supply a replacement or refund the purchase money but shall not be liable if the Products have been modified or used or maintained otherwise than in accordance with R&G's or manufacturer's instructions and good engineering practice or if the defect arises from accident or neglect. Other than identified above and subject to R&G not limiting its liability for causing death and personal injury, it shall not be liable for indirect or consequential loss and otherwise its liability shall be limited to the amounts paid by the Buyer for the Products or the fitting or service concerned. These terms do not affect the Buyer's statutory rights.

R&G RACING RETURNS POLICY (NON-FAULTY GOODS)

Returns must be pre-authorized (if not pre-authorized the return will be rejected). Goods may only be returned direct to us if they were purchased direct from us (customer must prove if necessary). Otherwise to be returned to original vendor. Goods must be in re-sellable condition, in the opinion of R&G Racing. All returns are subject to a 25% restocking and handling fee (25% of the gross value exc. P&P - at the prevailing price at time of purchase). The customer must pay any and all carriage charges. No returns of discontinued products, unless within 14 days of purchase. This policy does not affect your statutory rights and does not refer to faulty goods.

R&G Racing

Unit 1, Shelley's Lane, East Worldham, Alton, Hampshire, GU34 3AQ

Tel: +44 (0)1420 89007 Fax: +44 (0)1420 87301 www.rg-racing.com Email: info@rg-racing.com



NOTICE DE MONTAGE POUR LSR0001
PORTE BAGAGE LATÉRAL
YAMAHA TÉNÉRÉ 700 2019-



CE KIT CONTIENT LES ARTICLES ILLUSTRÉS ET ÉTIQUETES SUR LA PAGE.

CERTAINES PARTIES PEUVENT ÊTRE PRÉSENTES UNIQUEMENT POUR LA CLARTE DES INSTRUCTIONS.

NE PAS PROCÉDER AU MONTAGE TANT QUE VOUS N'ÊTES PAS SÛR QUE TOUTES LES PIÈCES SOIENT PRÉSENTES.

VEUILLEZ LIRE TOUTES LES INSTRUCTIONS AVANT DE CONTINUER.

EN CAS DE DOUTE LORS DU MONTAGE DE NOS PRODUITS, CONSULTEZ UN DE NOS REVENDEURS OU FAITES APPEL A UN TECHNICIEN QUALIFIÉ.

VEUILLEZ NOTER QUE LA FAÇON DONT LE KIT EST EMBALLÉ NE REPRÉSENTE PAS NECESSAIREMENT LA MANIÈRE DE LE MONTER SUR LA MOTO.

SI DES RONDELLES EN CAOUTCHOUC SONT UTILISÉES POUR MAINTENIR LES COMPOSANTS SUR LES BOULONS, ELLES PEUVENT ÊTRE JETÉES.

NOTICE DISPONIBLE AU TÉLÉCHARGEMENT SUR : WWW.RG-RACING.COM



<u>TOOLS REQUIRED</u>	<u>VALEURS DE SERRAGE</u>
<ul style="list-style-type: none"> • CLÉ À MOLETTE 13mm • CLÉ À CLIQUET + DOUILLE 13mm • CLÉ TORX T40 	M4 BOULON = 8Nm M5 BOULON = 12Nm M6 BOULON = 15Nm M8 BOULON = 20Nm M10 BOULON = 40Nm M12 BOULON = 40Nm

LÉGENDE

ARTICLE NO.	DESCRIPTION	QTÉ
ARTICLE 1	SMW0183 PORTE BAGAGE CÔTÉ GAUCHE	1
ARTICLE 2	SMW0183 PORTE BAGAGE CÔTÉ DROIT	1
ARTICLE 3	SMW0185 SUPPORT DE FIXATION GAUCHE	1
ARTICLE 4	SMW0186 SUPPORT DE FIXATION DROIT	1
ARTICLE 5	S1314 ENTRETOISE DE MONTAGE	4
ARTICLE 6	M8 x 1.25 x 80.00mm BOULON (SUPPORTS SUPÉRIEURS)	4
ARTICLE 7	M8 x 1.25 x 20mm BOULON (SUPPORTS INFÉRIEURS)	2
ARTICLE 8	M8 x 1.25 x 25mm BOULON (SUPPORTS REPOSE PIED)	4
ARTICLE 9	M8 x 1.25 ÉCROU	2
ARTICLE 10	M8 RONDELLE OD=19mm	12
ARTICLE 11	M8 CACHE BOULON	6



SCHÉMA D'ENSEMBLE CÔTÉ GAUCHE ET DROIT

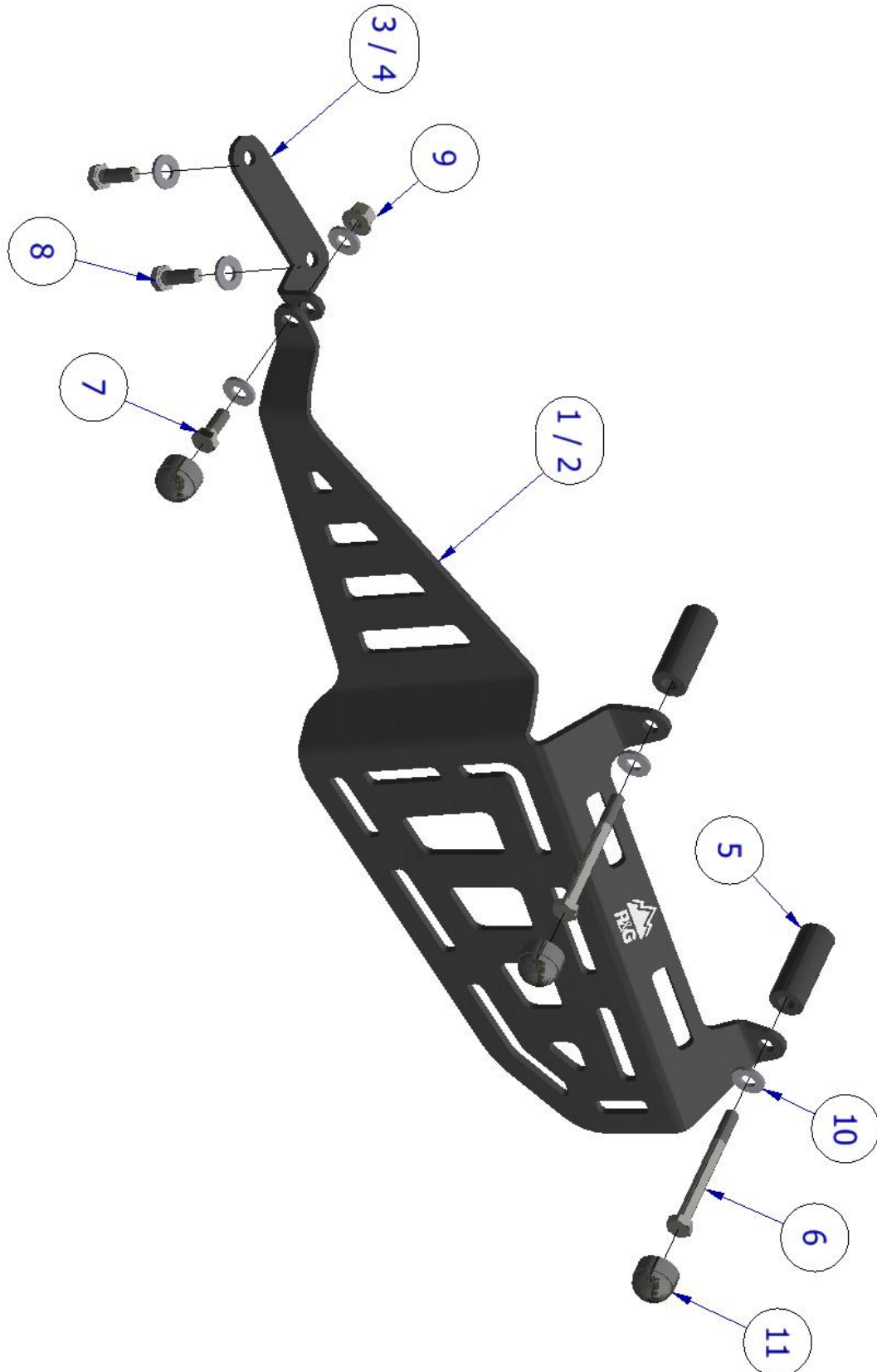



NOTICE DE MONTAGE

- Retirez les crochets d'origine des deux côtés de la moto comme indiqué sur la photo 1, à l'aide d'une clé Torx T40.
- Retirez les deux repose-pieds passager comme indiqué sur la photo 2 (ceux-ci peuvent être réinstallés plus tard, si vous le souhaitez).
- Si vous ne remettez pas en place les repose-pieds: en commençant par la gauche de la moto, à l'aide d'une douille de 13 mm et d'une clé, montez le support de montage côté gauche (article 3) avec 2 des boulons M8 x 25 mm inclus (article 8) et rondelles (article 10), comme indiqué sur la photo 3. La languette de montage doit être dirigée vers le haut et vers l'arrière de la moto, comme indiqué sur le schéma de la page 3.
- En cas de remontage des repose-pieds: prendre en sandwich le support de montage côté gauche (article 3) entre les trous de montage et la surface de montage du repose-pieds et le fixer avec les boulons d'origine.
- Faites glisser une rondelle (article 10) sur les 2x plus longs boulons M8 x 80 mm inclus (article 6), puis faites-la glisser à travers les trous de montage supérieurs du porte-bagages côté gauche (article 1). Placez une entretoise (article 5) sur la longueur du boulon exposé, puis offrez jusqu'aux trous de fixation du crochet d'origine, comme indiqué sur la photo 4. Serrez les boulons à l'aide d'une douille de 13 mm et d'une clé, pour donner une structure comme indiqué sur la photo 5.
- Alignez le trou de montage inférieur du porte-bagages avec le trou de la languette du support de montage précédemment installé, puis fixez l'ensemble à l'aide de l'un des boulons M8 x 20 mm inclus (article 7), rondelles (article 10) et écrous Nyloc M8 (article 9). Serrez à l'aide d'une douille de 13 mm et d'une clé, tout en maintenant l'écrou avec une clé de 13 mm, comme indiqué sur la photo 6.
- Répétez les étapes précédentes pour le côté droit de la moto, puis serrez à fond tous les boulons. Enfin, montez un capuchon de boulon (article 11) sur chacune des têtes de boulon.
- Ajustez votre choix de bagages souples, en les fixant aux porte-bagages à l'aide de sangles appropriées si nécessaire.
- **Si vous installez des bagages particulièrement grands / longs qui surplombent les porte-bagages, vous devrez en outre installer un pare chaleur R&G (code produit - ESG0002BK) pour éviter que les bagages n'entrent en contact avec le silencieux d'échappement pendant l'utilisation.**

**Avant de rouler avec des bagages montés, assurez-vous que tous les bagages soient entièrement sécurisés et ne touchent aucune partie de la chaîne ou du silencieux d'échappement pendant l'utilisation.
Le non-respect de cette consigne entraînera des dommages aux bagages et à la moto et peut entraîner des blessures graves ou la mort.**

ISSUE 1 - 02/03/2021 (FB)

R&G Racing

Unit 1, Shelley's Lane, East Worldham, Alton, Hampshire, GU34 3AQ

Tel: +44 (0)1420 89007 Fax: +44 (0)1420 87301 www.rg-racing.com Email: info@rg-racing.com