



FITTING INSTRUCTIONS FOR SP0082 SWINGARM PROTECTOR
HONDA CB1000R '18-



THIS KIT CONTAINS THE ITEMS PICTURED AND LABELLED BELOW.
DO NOT PROCEED UNTIL YOU ARE SURE ALL PARTS ARE PRESENT.

Please note that the way the kit is packed does not necessarily represent the way of mounting to the bike.

THE PARTS SHOWN MAY BE REPRESENTATIVE ONLY (FOR CLARITY OF INSTRUCTIONS ONLY).

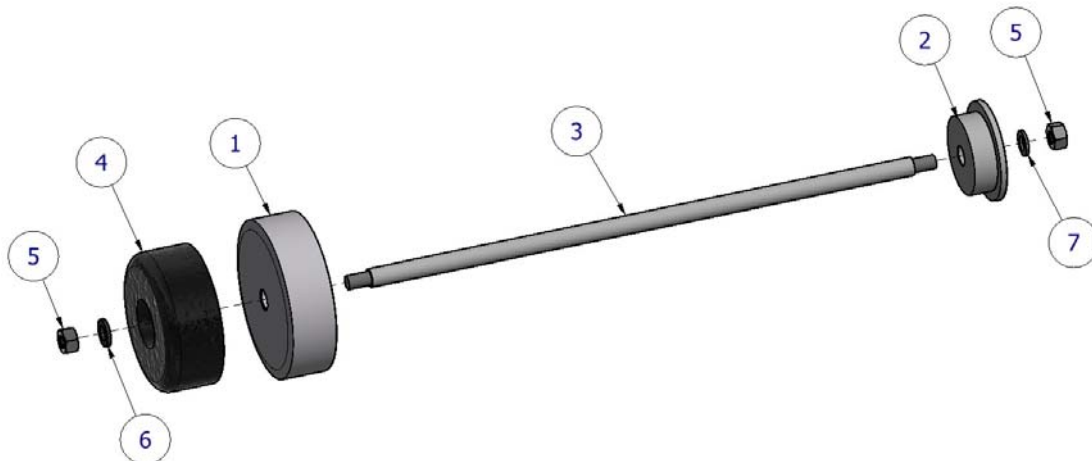

LEGEND

- ITEM 1 = LEFT SIDE MOUNTING BLOCK (M0560) (x1)
- ITEM 2 = RIGHT SIDE SPINDLE COVER (SC0009) (x1)
- ITEM 3 = SPINDLE BAR (SB130) (x1)
- ITEM 4 = BOBBIN (B0484) (x1)
- ITEM 5 = M6 NYLOC NUTS (x2)
- ITEM 6 = M6 WASHER (19mm OD) (x1)
- ITEM 7 = M6 WASHER (16mm OD) (x1)

R&G

Unit 1, Shelley's Lane, East Worldham, Alton, Hampshire, GU34 3AQ
 Tel: +44 (0)1420 89007 Fax: +44 (0)1420 87301 www.rg-racing.com Email: info@rg-racing.com



TOOLS REQUIRED

- 10mm socket and wrench (x2).

MAXIMUM TORQUE SETTINGS

- M4 BOLT = 8Nm
- M5 BOLT = 12Nm
- M6 BOLT = 15Nm
- M8 BOLT = 20Nm
- M10 BOLT = 40Nm

FITTING INSTRUCTIONS

- Position the larger diameter M6 washer (item 6) and one M6 nyloc nut (item 5) onto either threaded end of the spindle bar (item 3). Ensure that the nyloc nut is fully engaged to the thread.
- Locate the bobbin (item 4) followed by the mounting block (item 1) onto the bar, so the nut and washer sit inside the counterbore on the bobbin. Position through the rear axle from the left side of the bike, ensuring the mounting block locates over the spindle nut.
- Fit the right side spindle cover (item 2) into the hole in the right side of the wheel ensuring the spindle bar protrudes through the spindle cover.
- Fit the remaining washer (item 7) and nyloc nut (item 5) to the exposed thread on the spindle bar and tighten.
- Ensure that the components assembled match the exploded diagram shown on page 1. Fully tighten the nyloc nuts on both sides. Do not overtighten – the nyloc nuts will hold it tight.

ISSUE 14/08/2018 (HB)

Digital copies of these instructions are available to download from www.rg-racing.com

CONSUMER NOTICE

The catalogue description and any exhibition of samples are only broad indications of the Products and R&G may make design changes which do not diminish their performance or visual appeal and supplying them in such state shall conform to the order. The Buyer acknowledges no representation or warranty (other than as to title) has been given or will apply to the Products other than those in R&G's order or confirmation and the Buyer confirms it has chosen the Products as being of merchantable quality and suitable for its particular purposes. Where R&G fits the Products or undertakes other services it shall exercise reasonable skill and care and rectify any fault free of charge unless the workmanship has been disturbed. The Buyer is responsible for ensuring that the warranty on the motorcycle is not affected by the fitting of the Products. On return of any defective Products R&G shall at its option either supply a replacement or refund the purchase money but shall not be liable if the Products have been modified or used or maintained otherwise than in accordance with R&G's or manufacturer's instructions and good engineering practice or if the defect arises from accident or neglect. Other than identified above and subject to R&G not limiting its liability for causing death and personal injury, it shall not be liable for indirect or consequential loss and otherwise its liability shall be limited to the amounts paid by the Buyer for the Products or the fitting or service concerned. These terms do not affect the Buyer's statutory rights.

R&G RETURNS POLICY (NON-FAULTY GOODS)

Returns must be pre-authorised (if not pre-authorised the return will be rejected). Goods may only be returned direct to us if they were purchased direct from us (customer must prove if necessary). Otherwise to be returned to original vendor. Goods must be in re-sellable condition, in the opinion of R&G. All returns are subject to a 25% restocking and handling fee (25% of the gross value exc. P&P – at the prevailing price at time of purchase). The customer must pay any and all carriage charges. No returns of discontinued products, unless within 14 days of purchase. This policy does not affect your statutory rights and does not refer to faulty goods.

R&G

Unit 1, Shelley's Lane, East Worldham, Alton, Hampshire, GU34 3AQ

Tel: +44 (0)1420 89007 Fax: +44 (0)1420 87301 www.rg-racing.com Email: info@rg-racing.com



**NOTICE DE MONTAGE POUR SP0082 PROTECTION BRAS OSCILLANT
HONDA CB1000R '18-**

Page | 3



**LE KIT CONTIENT LES ARTICLES EXPOSES CI-DESSOUS, VERIFIER QUE TOUTES LES PIECES SOIENT PRESENTES AVANT
DE PROCEDER AU MONTAGE.**

**LA FAÇON DONT LE KIT EST EMBALLE NE CORRESPOND PAS FORCEMENT A LA FAÇON DE MONTER LES PIECES SUR LA
MOTO.**

LES PARTIES PRESENTEES PEUVENT ETRE UNIQUEMENT REPRESENTATIVES (POUR LA CLARTE DES INSTRUCTIONS UNIQUEMENT).

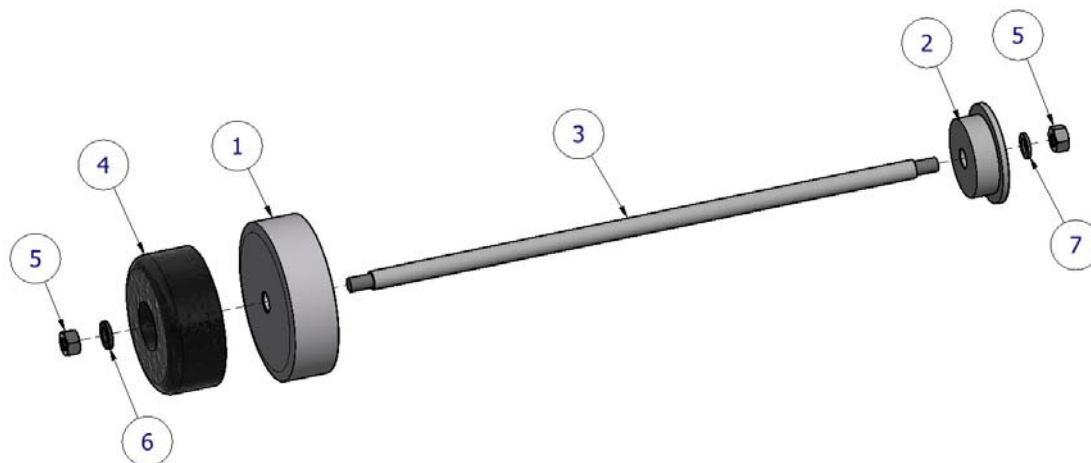

LÉGENDE

- ARTICLE 1 = BLOC DE MONTAGE CÔTÉ GAUCHE (M0560) (x1)
 ARTICLE 2 = CACHE MOYEU CÔTÉ DROIT (SC0009) (x1)
 ARTICLE 3 = AXE MOYEU (SB130) (x1)
 ARTICLE 4 = BOBINE (B0484) (x1)

R&G

Unit 1, Shelley's Lane, East Worldham, Alton, Hampshire, GU34 3AQ
 Tel: +44 (0)1420 89007 Fax: +44 (0)1420 87301 www.rg-racing.com Email: info@rg-racing.com



ARTICLE 5 = M6 ÉCROUS (x2)
 ARTICLE 6 = M6 RONDELLE (19mm OD) (x1)
 ARTICLE 7 = M6 RONDELLE (16mm OD) (x1)

OUTILS REQUIS

- Clé à cliquet + douilles 10mm (x2).

VALEURS DE SERRAGE RECOMMANDEES

M4 BOULON = 8Nm
 M5 BOULON = 12Nm
 M6 BOULON = 15Nm
 M8 BOULON = 20Nm
 M10 BOULON = 40Nm

NOTICE DE MONTAGE

- Positionner la rondelle M6 (article 6) et un écrou M6 (article 5) sur chaque extrémité filetée de l'axe de moyeu (article 3). Veiller à ce que l'écrou soit complètement engagé sur le filetage.
- Placer la bobine (article 4) suivie d'un bloc de montage (article 1) sur l'axe, de façon à ce que l'écrou et la rondelle se placent dans le contre alésage de la bobine. Positionnez la dans le moyeu arrière du côté gauche de la moto, en veillant à ce que le bloc de montage se place sur l'écrou d'axe.
- Monter le cache moyeu du côté droit (article 2) dans le trou du côté droit de la roue en veillant à ce que l'axe de moyeu dépasse du cache moyeu.
- Insérer la rondelle restante (article 7) et l'écrou (article 5) sur le filetage exposé de l'axe de moyeu puis serrer.
- Veiller à ce que l'ensemble corresponde au schéma présenté en page 1. Serrer complètement les écrous des 2 côtés. Ne pas trop serrer – les écrous fixent l'ensemble.

ISSUE 14/08/2018 (HB)

Notice disponible au téléchargement sur www.rg-racing.com

CONSUMER NOTICE

The catalogue description and any exhibition of samples are only broad indications of the Products and R&G may make design changes which do not diminish their performance or visual appeal and supplying them in such state shall conform to the order. The Buyer acknowledges no representation or warranty (other than as to title) has been given or will apply to the Products other than those in R&G's order or confirmation and the Buyer confirms it has chosen the Products as being of merchantable quality and suitable for its particular purposes. Where R&G fits the Products or undertakes other services it shall exercise reasonable skill and care and rectify any fault free of charge unless the workmanship has been disturbed. The Buyer is responsible for ensuring that the warranty on the motorcycle is not affected by the fitting of the Products. On return of any defective Products R&G shall at its option either supply a replacement or refund the purchase money but shall not be liable if the Products have been modified or used or maintained otherwise than in accordance with R&G's or manufacturer's instructions and good engineering practice or if the defect arises from accident or neglect. Other than identified above and subject to R&G not limiting its liability for causing death and personal injury, it shall not be liable for indirect or consequential loss and otherwise its liability shall be limited to the amounts paid by the Buyer for the Products or the fitting or service concerned. These terms do not affect the Buyer's statutory rights.

R&G RETURNS POLICY (NON-FAULTY GOODS)

Returns must be pre-authorised (if not pre-authorised the return will be rejected). Goods may only be returned direct to us if they were purchased direct from us (customer must prove if necessary). Otherwise to be returned to original vendor. Goods must be in re-sellable condition, in the opinion of R&G. All returns are subject to a 25% restocking and handling fee (25% of the gross value exc. P&P – at the prevailing price at time of purchase). The customer must pay any and all carriage charges. No returns of discontinued products, unless within 14 days of purchase. This policy does not affect your statutory rights and does not refer to faulty goods.

R&G

Unit 1, Shelley's Lane, East Worldham, Alton, Hampshire, GU34 3AQ
 Tel: +44 (0)1420 89007 Fax: +44 (0)1420 87301 www.rg-racing.com Email: info@rg-racing.com



**MONTAGEANLEITUNG FÜR SP0082 SCHWINGENPROTEKTOR
HONDA CB1000R '18-**



Page | 5

**ALLE KIT-TEILE SIND UNTEN ABGEBILDET UND GEKENNZEICHNET. ÜBERPRÜFEN SIE, DASS
ALLE TEILE VORHANDEN SIND BEVOR SIE MIT DER MONTAGE BEGINNEN.**

Hinweis: Die Verpackung der Teile stellt nicht die Reihenfolge der Montage dar.

DIE UNTEN ABGEBILDETEN TEILE DIENEN LEDIGLICH ZUR ERKLÄRUNG

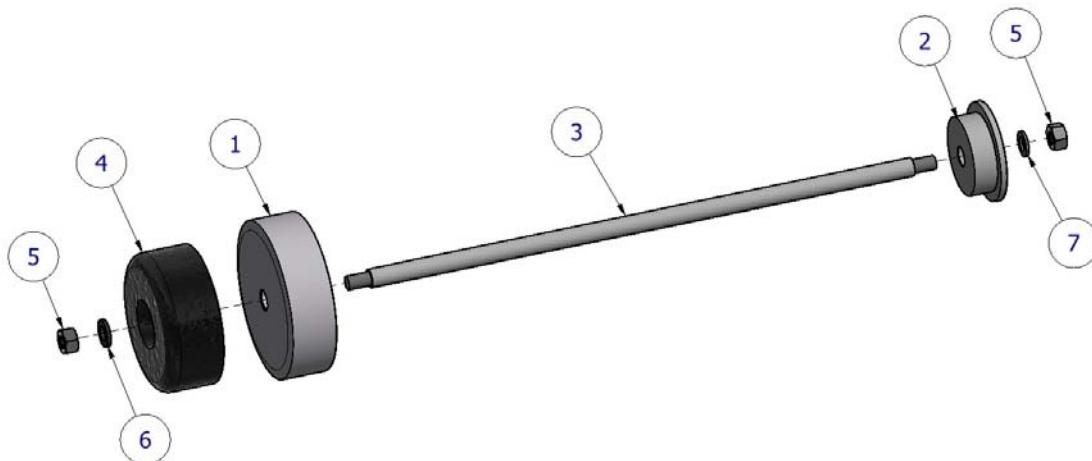

LIEFERUMFANG

- ARTIKEL 1 = LINKE SEITE - MONTAGE BLOCK (M0560) (x1)
- ARTIKEL 2 = RECHTE SEITE ABDECKUNG FÜR DIE ACHSE (SC0009) (x1)
- ARTIKEL 3 = VERBINDUNGSSTANGE (SB130) (x1)
- ARTIKEL 4 = BOBBIN (B0484) (x1)
- ARTIKEL 5 = M6 SELBSTSICHERNDE MUTTER (x2)
- ARTIKEL 6 = M6 UNTERLEGSCHIEBE (19mm OD) (x1)
- ARTIKEL 7 = M6 UNTERLEGSCHIEBE (16mm OD) (x1)

R&G

Unit 1, Shelley's Lane, East Worldham, Alton, Hampshire, GU34 3AQ
Tel: +44 (0)1420 89007 Fax: +44 (0)1420 87301 www.rg-racing.com Email: info@rg-racing.com



SIE BENÖTIGEN FOLGENDES WERKZEUG

- Steckschlüsselsatz mit 2x 10mm Steckschlüssel.

MAX. ANZUGSDREHMOMENT

- M4 SCHRAUBE = 8Nm
- M5 SCHRAUBE = 12Nm
- M6 SCHRAUBE = 15Nm
- M8 SCHRAUBE = 20Nm
- M10 SCHRAUBE = 40Nm

MONTAGEANLEITUNG

- Die M6 Unterlegscheibe mit dem größeren Durchmesser (Artikel 6) und eine M6 selbstsichernde Mutter (Artikel 5) an einem Ende der Verbindungsstange (Artikel 3) fixieren. Stellen Sie sicher, dass die selbstsichernde Mutter am Gewinde eingerastet ist.
- Den Bobbin (Artikel 4) gefolgt vom Montageblock (Artikel 1) an der Stange anbringen, so dass die Mutter und Unterlegscheibe innerhalb der Gegenbohrung im Bobbin passen. Von der linken Seite des Motorrads durch die Hinterachse einführen – bitte darauf achten, dass der Montageblock über der Radmutter positioniert ist.
- Montieren Sie die Abdeckung für die rechte Achse (Artikel 2) in der Öffnung an der rechten Seite des Rad – bitte darauf achten, dass die Verbindungsstange durch die Abdeckung hervorsteht.
- Die übrige Unterlegscheibe (Artikel 7) und selbstsichernde Mutter (Artikel 5) am hervorstehenden Gewinde der Verbindungsstange anbringen und befestigen.
- Bitte stellen Sie sicher, dass die Montage der Komponenten mit der Explosionszeichnung auf Seite 1 übereinstimmt. Ziehen Sie die selbstsichernden Muttern an beiden Seiten fest. Nicht zu stark anziehen – die selbstsichernden Muttern halten das fest.

AUSGABE 14/08/2018 (HB)

Eine digitale Version dieser Montageanleitung kann auf folgender Seite heruntergeladen werden:

www.rg-racing.com

CONSUMER NOTICE

The catalogue description and any exhibition of samples are only broad indications of the Products and R&G may make design changes which do not diminish their performance or visual appeal and supplying them in such state shall conform to the order. The Buyer acknowledges no representation or warranty (other than as to title) has been given or will apply to the Products other than those in R&G's order or confirmation and the Buyer confirms it has chosen the Products as being of merchantable quality and suitable for its particular purposes. Where R&G fits the Products or undertakes other services it shall exercise reasonable skill and care and rectify any fault free of charge unless the workmanship has been disturbed. The Buyer is responsible for ensuring that the warranty on the motorcycle is not affected by the fitting of the Products. On return of any defective Products R&G shall at its option either supply a replacement or refund the purchase money but shall not be liable if the Products have been modified or used or maintained otherwise than in accordance with R&G's or manufacturer's instructions and good engineering practice or if the defect arises from accident or neglect. Other than identified above and subject to R&G not limiting its liability for causing death and personal injury, it shall not be liable for indirect or consequential loss and otherwise its liability shall be limited to the amounts paid by the Buyer for the Products or the fitting or service concerned. These terms do not affect the Buyer's statutory rights.

R&G RETURNS POLICY (NON-FAULTY GOODS)

Returns must be pre-authorized (if not pre-authorized the return will be rejected). Goods may only be returned direct to us if they were purchased direct from us (customer must prove if necessary). Otherwise to be returned to original vendor. Goods must be in re-sellable condition, in the opinion of R&G. All returns are subject to a 25% restocking and handling fee (25% of the gross value exc. P&P – at the prevailing price at time of purchase). The customer must pay any and all carriage charges. No returns of discontinued products, unless within 14 days of purchase. This policy does not affect your statutory rights and does not refer to faulty goods.

R&G

Unit 1, Shelley's Lane, East Worldham, Alton, Hampshire, GU34 3AQ

Tel: +44 (0)1420 89007 Fax: +44 (0)1420 87301 www.rg-racing.com Email: info@rg-racing.com