



MODEL

Yamaha X-Max 400 2013

LINE

URBAN

SCHEMATIC

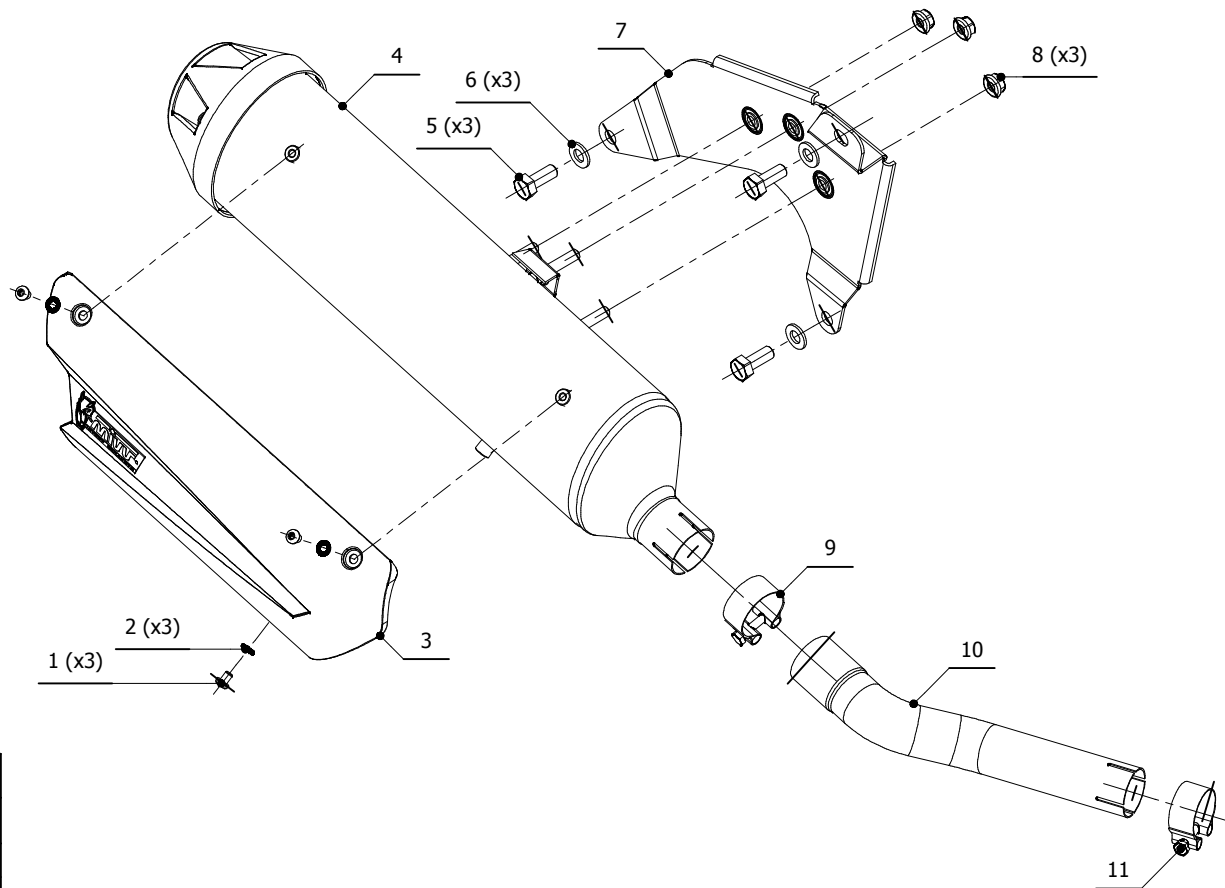
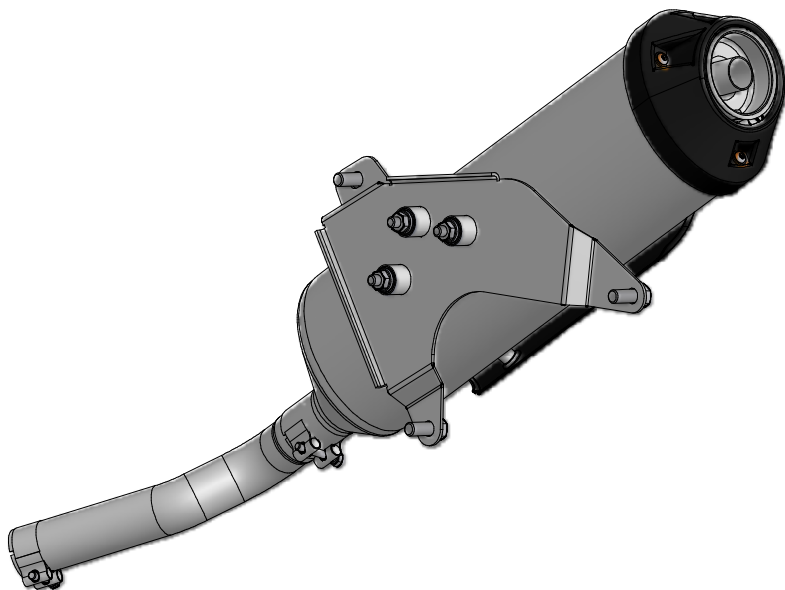

ELENCO PARTI / PARTS LIST

#	QTÀ / QTY	DESCRIZIONE / DESCRIPTION	CODICE / CODE
1	3	Vite M6 x 8 / Screw M6 x 8	50.72.026.1
2	3	Rondella di sicurezza M6 / Safety washer M6	50.73.131.1
3	1	Copertura in alluminio / Aluminium cover	50.CR.010.1
4	1	Silenziatore / Muffler	URBAN
5	3	Vite M10x25 / Screw M10x25	50.73.183.1
6	3	Rondella M10 / Washer M10	50.73.013.1
7	1	Staffa Urban / Urban bracket	50.SS.817.0
8	3	Dado M8 flangiato / Flanged nut M8	50.73.393.1
9	1	Fascetta Ø 40/43 mm / Pipe clamp Ø 40/43 mm	50.FA.005.1
10	1	Tubo di raccordo / Link pipe	97CYA0009B
11	1	Fascetta Ø 37/40 mm / Pipe clamp Ø 37/40 mm	50.FA.003.1

APPLICAZIONI / APPLICATIONS

CODICE / CODE	SILENZIATORE / MUFFLER	CODICE OMOL. / HOMOL. CODE
C.YA.0009.B	NON CATALIZZATO / NON CATALYZED	ME041 e9 1309
C.YA.0009.K	CATALIZZATO / CATALYZED	ME041 e9 1309 ME050 e3 1001